

# AIPER®

## CORDLESS ROBOTIC POOL CLEANER ROBOT DE PISCINE SANS FIL

Aiper Scuba X1 Pro Max

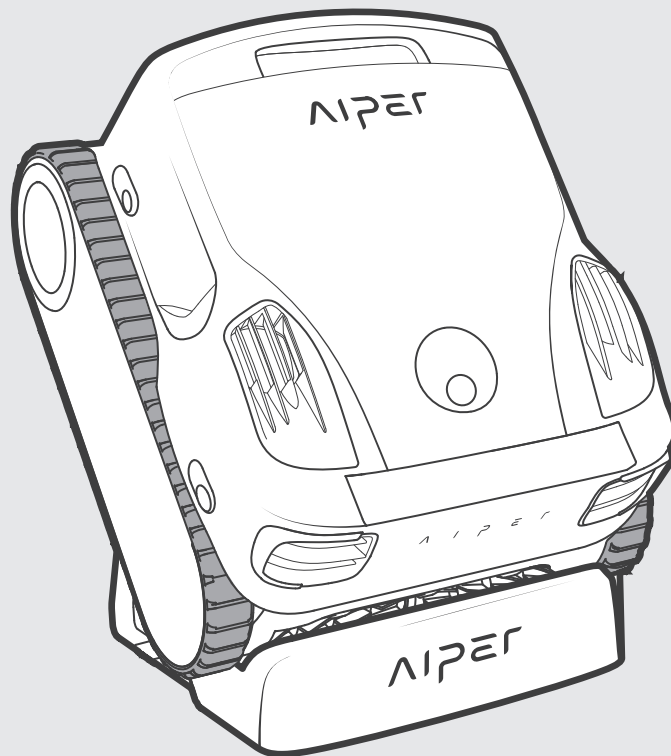

User Manual / Manuel d'utilisation



# LANGUAGE / LANGUE

EN	User Manual -----	1
FR	Manuel d'utilisation -----	22
ES	Manual de usuario -----	43

Thank you for choosing Aiper.

You've now joined millions who have already trusted Aiper to care for their pools and are enjoying the convenience of a pristinely clean pool.

This user manual will help you maintain your device and ensure it performs at its maximum efficiency for years to come. Please take a moment to read through it.

If you have any questions, please visit our website at [www.aiper.com](http://www.aiper.com) and contact our customer service team for assistance or more information.

### Aiper Customer Service:

Country	Toll Free Number	Language
US	+1 8668500666	English
CA	+1 8668500666	English
AU	+61 1800497023	English



Email: [service@aiper.com](mailto:service@aiper.com)



Scan for  
Video Guide



Scan the QR  
Code to Access  
Customer Support

# 1 IMPORTANT SAFETY INSTRUCTIONS

Please read this manual carefully and follow all warnings and instructions when using your Aiper Cordless Robotic Pool Cleaner (hereinafter referred to as *device*). Failure to comply may result in electric shock, fire, or serious injury. Aiper is not liable for any losses or injuries caused by improper use of this device.

For your safety and the optimal performance of this device, please read and follow these instructions:

## 1. READ AND FOLLOW ALL INSTRUCTIONS

2. The device can be used by persons with reduced physical, sensory or mental capabilities or lack of experience and knowledge if they have been given supervision or instruction concerning use of the device in a safe way and if they understand the hazards involved.
3. Children shall not play with the device. This device shall not be used by children. Cleaning and user maintenance shall not be carried out by children.
4. **WARNING:** To reduce the risk of injury, do not permit children to use this product unless they are closely supervised at all times.
5. Ensure that children do not attempt to touch the device while it is operating.
6. Do not allow children to ride the device under any circumstance.
7. Do not operate the device with people or animals in the pool.
8. While operational, do not place your hands into any part of the device as this may result in injury.
9. Prevent unintentional starting. Ensure the power button is off before connecting to the battery pack, picking up, or carrying the device. Carrying the device with your finger on the power button or energizing the device with the power button on invites accidents.
10. **CAUTION:** This pump is for use with permanently-installed pools. Do not use with storable pools. A permanently-installed pool is constructed in or on the ground or in a building such that it cannot be readily disassembled for storage. A storable pool is constructed so that it is capable of being readily disassembled for storage and reassembled to its original integrity.
11. Do not run your device out of the water as it may lead to over-heating.
12. The device can only be charged with the specific wireless charging dock (model: CHW1), which is powered by the specific charger (model: GM95-294300-1FGN, GM95-294300-4FGN).
13. Do not place any objects between the device and the wireless charging dock. The device may fail to charge properly or overheat and get damaged as a result.
14. A charger that is suitable for one type of battery pack may create a risk of fire when used with another battery pack.
15. This device can only be used with C1264B4-04 or C1264B4-03 model lithium battery packs.
16. This device contains batteries that are non-replaceable. When the battery is at end of life, the device shall be properly disposed of.
17. In the event a damaged device produces an unfamiliar liquid, avoid contact with the liquid. If coming into contact with a foreign liquid, especially the eyes or other sensitive parts, immediately flush with water. Liquid ejected from a damaged battery may cause skin irritation or burns.
18. Do not use a battery pack or device that is damaged or modified. Damaged or modified batteries may exhibit unpredictable behavior resulting in fire, explosion, or risk of injury.
19. Do not expose a battery pack or device to fire or excessive temperature. Exposure to fire or temperature above 158°F (70°C) may cause explosion.

20. Follow all charging instructions and do not charge the battery pack or device outside of the temperature range specified in the instructions. Charging improperly or at temperatures outside of the specified range may damage the battery and increase the risk of fire.
21. **WARNING** : Risk of Electric Shock. Connect only to a grounding type receptacle. If replacement of the plug or cord is needed, use only identical replacement parts.
22. **CAUTION**: To reduce the risk of electric shock, the pool must be installed no closer than 6 feet (1.8 m) from any electrical outlet. Do not place portable devices closer than 5 feet (1.5 m) from the pool.
23. Ensure your device is turned off and the charging port is dry before charging with the charger. While charging, your device should be kept in a cool, well-ventilated area. Do not cover your device while charging, as this may cause components to overheat.
24. **WARNING**: To reduce the risk of electric shock, do not use an extension cord to charge your device and instead only charge is via a dedicated wall outlet.
25. **WARNING**: To reduce the risk of electric shock, replace damaged cord immediately.
26. If the power cord is damaged, it must be replaced or repaired by a qualified electrician or Aiper Customer Care to avoid any hazards.
27. Only certified professionals should disassemble the sealed drive kit of your device.
28. Your device should only be serviced by a qualified technician using official replacement parts.
29. Do not operate your device simultaneously with any other pool equipment, such as a pool filter, cleaner, or skimmer.
30. Operate the device when the pool's water pump is off to prevent it from getting stuck in the drain.
31. When putting your device into the water, the top of the device must face upwards and should never be placed upside down or thrown into the swimming pool.
32. Watch your steps and maintain balance when working near the poolside.
33. Do not drop, pierce the shell, or intentionally damage the device in any way, as this may void your warranty.
34. Ensure the device is turned off while not in use or while performing maintenance.
35. When not in use, store the device indoors, in a cool, well-ventilated area.
36. The device is not protected against the effect of freezing. It shall not be left outside during freezing weather conditions.
37. Complies with 21CFR 1040.10 and 1040.11 except for conformance with IEC 60825-1 Ed.3., as described in Laser Notice No.56, dated May 8, 2019.
38. **CAUTION**:
  - FOR USE WITH SWIMMING POOLS ONLY.
  - FOR USE ONLY WITH AUTHORIZED AIPER WIRELESS CHARGER DOCK, MODEL: CHW1.

## SAVE THESE INSTRUCTIONS

**FCC Statement**

This device complies with Part 15 of the FCC Rules. Operation is subject to the following two conditions: (1) This device may not cause harmful interference, and (2) this device must accept any interference received, including interference that may cause undesired operation.

Warning: Changes or modifications not expressly approved by the party responsible for compliance could void the user's authority to operate the equipment.

Note: This equipment has been tested and found to comply with the limits for a Class B digital device, pursuant to Part 15 of the FCC Rules. These limits are designed to provide reasonable protection against harmful interference in a residential installation.

This equipment generates, uses, and can radiate radio frequency energy and, if not installed and used in accordance with the instructions, may cause harmful interference to radio communications. However, there is no guarantee that interference will not occur in a particular installation. If this equipment does cause harmful interference to radio or television reception, which can be determined by turning the equipment off and on, the user is encouraged to try to correct the interference by one or more of the following measures:

- (1) Reorient or relocate the receiving antenna.
- (2) Increase the separation between the equipment and receiver.
- (3) Connect the equipment into an outlet on a circuit different from that to which the receiver is connected.
- (4) Consult the dealer or an experienced radio/TV technician for help.

**Radiation Exposure Statement:**

1. This device complies with FCC radiation exposure limits set forth for an uncontrolled environment.
2. This device should be installed and operated with minimum distance 20cm between the radiator & your body.

**Importer:** Aiper Intelligent, LLC.

Address: 8735 Dunwoody Place, STE 6, Atlanta, Georgia 30350, USA. (Not for Return)

US Toll-Free: +18668500666

AU Toll-Free: +611800497023

**IC Statements**

This device contains licence-exempt transmitter(s)/receiver(s) that comply with Innovation, Science and Economic Development Canada's licence-exempt RSS(s). Operation is subject to the following two conditions: (1) This device may not cause interference, and (2) This device must accept any interference, including interference that may cause undesired operation of the device.

CAN ICES-3(B)/NMB-3(B)

**Radiation Exposure Statement:**

1. This device complies with IC radiation exposure limits set forth for an uncontrolled environment.
2. This device should be installed and operated with minimum distance 20cm between the radiator & your body.

## 2 Product Components

### 2.1 Package Contents

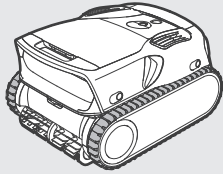

Scuba X1 Pro Max × 1

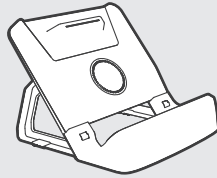

Charging Dock × 1

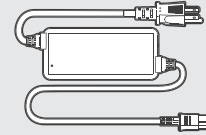

Charger × 1

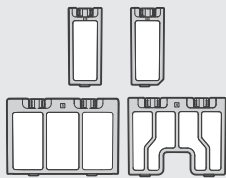

Replaceable MicroMesh™ Ultra-fine Filter × 1



Hook × 1



User Manual × 1

### 2.2 Component Overview

#### Robotic Pool Cleaner (Side View)

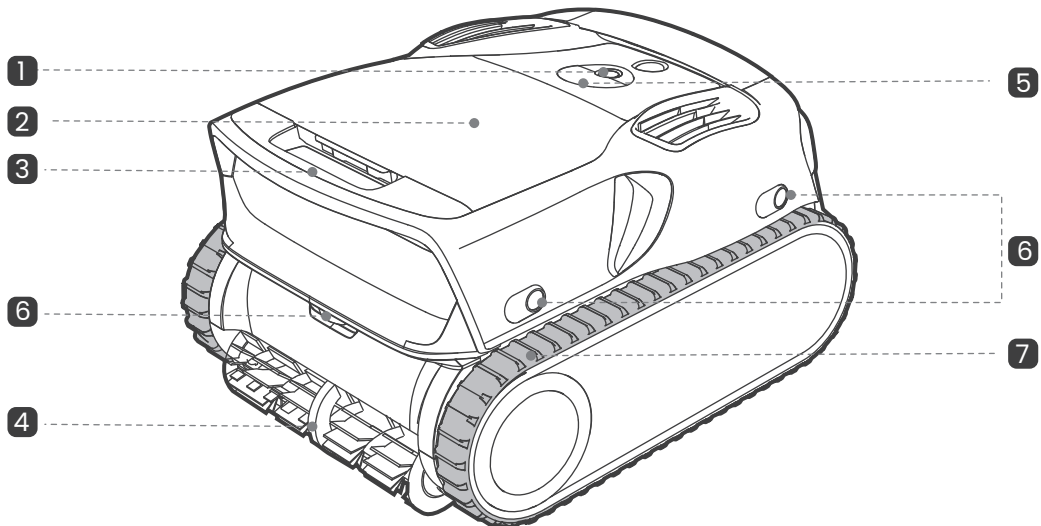

1 : Power Button

2 Top Shell

3 Handle

4 Roller Brush

5 LED Status Indicator

6 Ultrasonic Sensor

7 Caterpillar Tread

## Filter Box

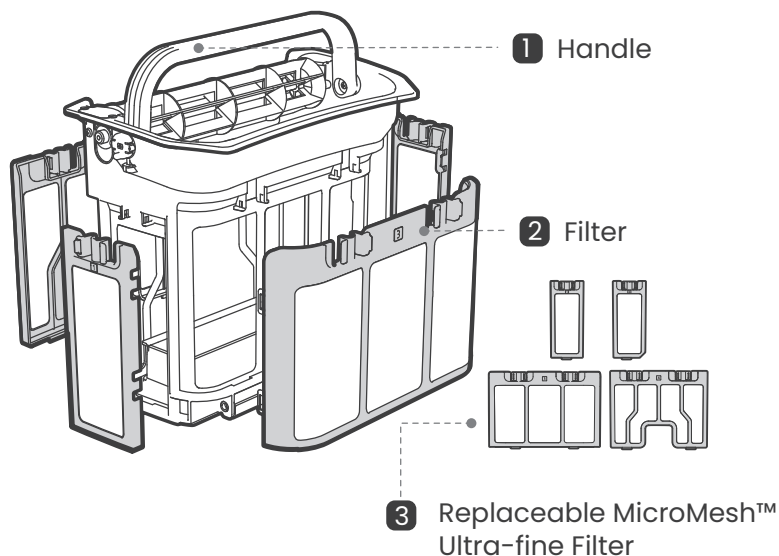

### Notes:

- A replaceable MicroMesh™ ultra-fine filter is included with the purchase of this device. For filtering finer debris like sand, dirt, and certain types of algae, it is recommended to use this filter instead of the standard one for improved performance.
- To replace the filter, press the latch to remove the existing one, and then insert the replaceable MicroMesh™ ultra-fine filter. Press it firmly until you hear a *click*, indicating that the filter is securely in place.

## Control Panel

### LED Status Indicator

### Mode Indicator





- Hero Mode  
(Floor+Wall+Skimming)
- Floor Mode
- Floor + Wall Mode
- Skimming Mode

If all the LED mode indicators are constantly lit, it indicates that the device is performing a custom task.

### Mode Button

Change and select cleaning mode.

### Power Button

- Press and hold  button for 2 seconds to turn on/off.
- Press and hold buttons  and  simultaneously for 5 seconds to enter network setup mode .
- Press and hold buttons  and  simultaneously for 5 seconds to reset the device to factory settings.

### Wi-Fi Indicator

### Cleaning Intensity Indicator

- ECO: Energy-Saving Cleaning
- AUTO: Adaptive Cleaning
- MAX: High-Performance Cleaning

### Cleaning Intensity Button

Change and select cleaning intensity.



## 3 How to Use Your Aiper Scuba X1 Pro Max

### 3.1 Operating Conditions

Please ensure the device is only used within the specified pool environments. Damage resulting from use outside these conditions will not be covered under warranty.

- **Water Temperature:** 32-104°F (0-40°C)
- **pH Value:** 7.0-7.8
- **Chlorine:** Maximum 4 ppm
- **NaCl:** Maximum 5000 ppm

### 3.2 Downloading the App

Download the Aiper App to unlock more features for your device:

You can download and install the Aiper App by scanning the QR code below or by searching for *Aiper* in your App store.



#### Notes:

- iOS 12.0 or later, or Android 8.0 or later is required for full App functionality on your smartphone or device.
- Once installed, follow the App's instructions to complete registration, login, and network setup.

### 3.3 Network Setup

When first powering on the device, it will enter Network Setup Mode. If this process is interrupted, press (U) + (L:) for 5 seconds to re-enter Network Setup Mode.

**Once in Network Setup Mode, please select either Bluetooth Setup or QR Code Setup.**

- **Bluetooth Setup:** Enable Bluetooth on your phone and grant access to the Aiper App. In the App, tap the [+] symbol in the top right corner, then select *Add via Bluetooth*. The App will detect nearby Bluetooth devices. Select your network, enter the Wi-Fi password, and tap *Next* to finish network setup.
- **QR Code Setup:** Open the App and tap the [+] in the top right corner, then select *Add via QR Code*. Scan the QR Code located on your Aiper device. When the device is recognized, follow the App's instructions to connect to the device's Wi-Fi. Once connected, return to the App and follow the prompts to complete the network setup.

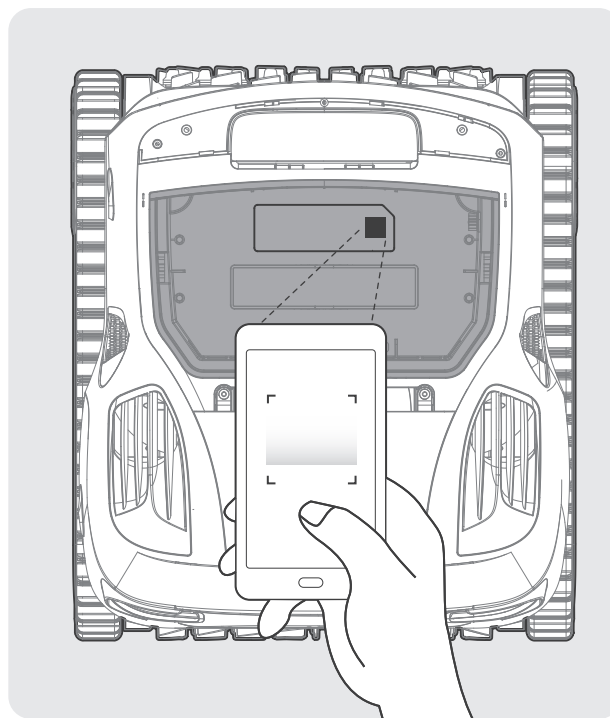

Wi-Fi Network Requirements:  
Use a 2.4GHz network or a dual-band network (2.4GHz and 5GHz).

### 3.4 Charging

**CAUTION:**

Please fully charge the device before using it to clean the pool.

Do not charge the device in direct sunlight.

It's advised that a minimum distance of 11.5 ft (3.5m) separates your pool and charging location. For the best results, your charging location should have Wi-Fi coverage, as this will expedite OTA updates.

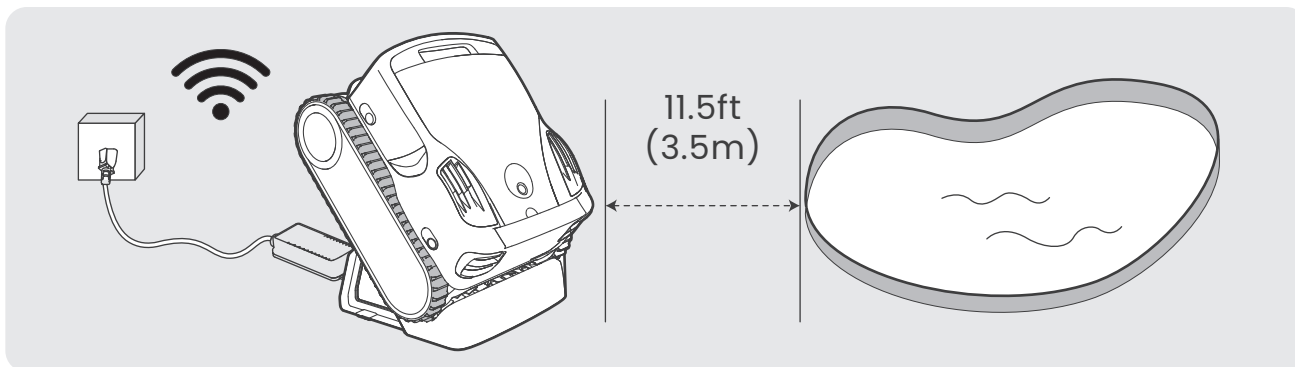

**Charging Options:**

Notes:

- Place the device in the center of the wireless charging dock until you hear a *beep*. The LED indicator will pulse green, indicating that charging has started. Fully charge the device before use.
- For Aiper Caddy users, skip these steps and follow the *Aiper Caddy Installation Guide* instead.

**1. Install the Charging Dock:** Insert the support leg into the charging panel. Then, attach the front cover.

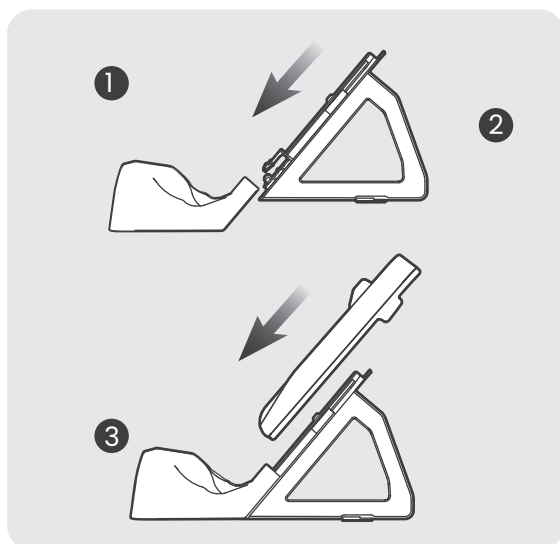

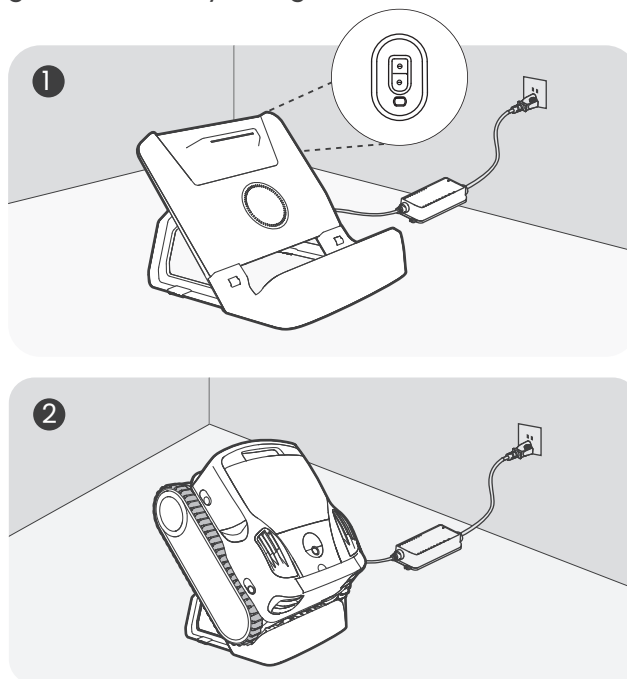

**2. Connect the charger's cable to the charging port on the dock, and plug the adapter into any available outlet. Place the device onto the charging dock. The LED status indicator on the device will pulse while charging and turn solid green when fully charged.**

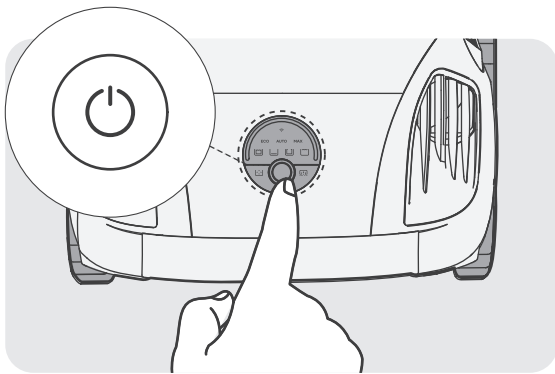

### 3.5 Cleaning Process

1. Press and hold  button for 2 seconds to turn on/off the device.





2. Press  button briefly to cycle through and select one of the four preprogrammed cleaning modes: Hero Mode, Floor Mode, Floor + Wall Mode, and Skimming Mode. Additional modes are available in the Aiper App.

Before submerging the device into the water, place the device on a horizontal surface for 5 seconds. After being submerged for a short period, the device will initiate the selected mode's cleaning task.

3. When the device is initially submerged, selecting a mode including pool floor cleaning will trigger the mapping process. The device will clean along the pool's floor contour to create an underwater map.

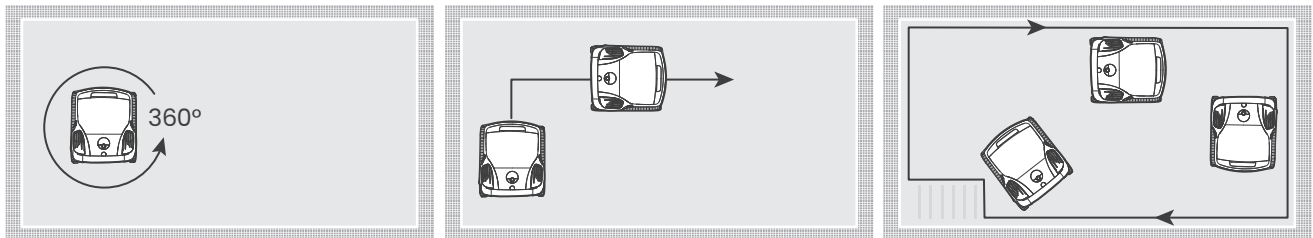
After a successful mapping, there's no need to do mapping again for the same pool. However, before each cleaning, the device need to briefly move around the floor to relocate.



After the mapping is done, the device will automatically recognize the pool's shape and initiate the  -shaped cleaning route when cleaning the pool floor. Once cleaning is finished, the device will return to the missed areas.

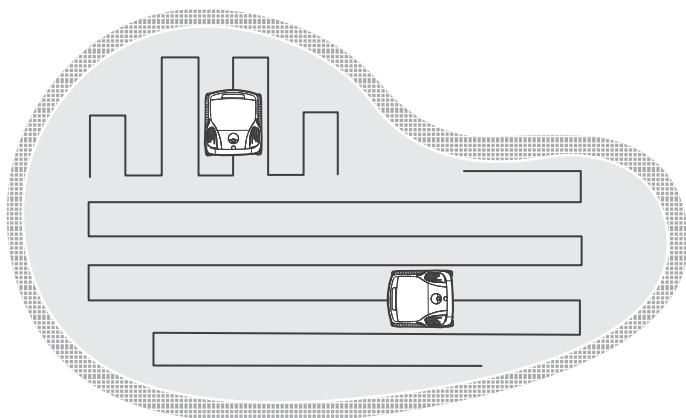
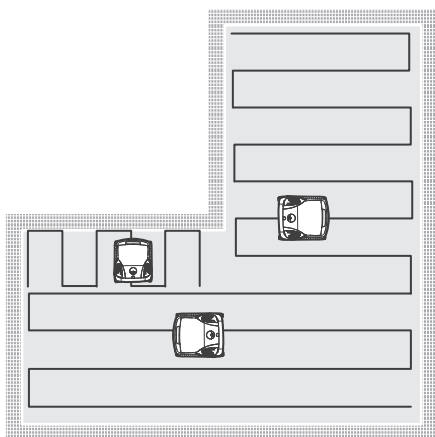

4. The details of each cleaning mode are described below:

- **Hero Mode:** The device will clean the pool floor, pool walls, and water surface sequentially. While cleaning the walls, it will clean the waterline at the same time.

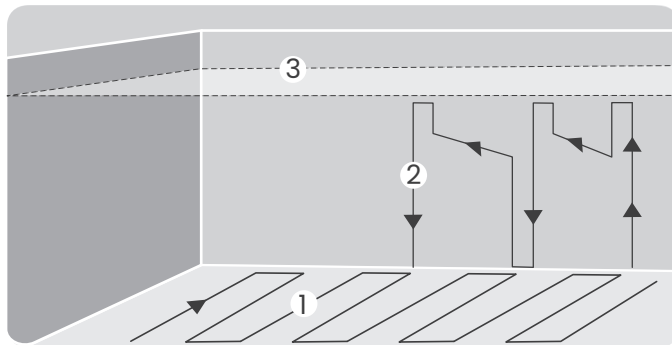
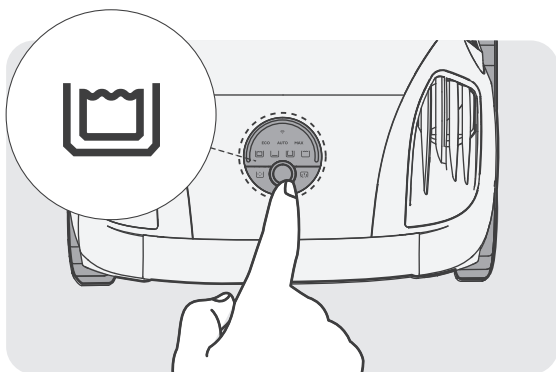

Hero Mode

- **Floor Mode:** The device will clean the pool floor utilizing a  $\sqcap$ -shaped route, without climbing or cleaning pool walls.

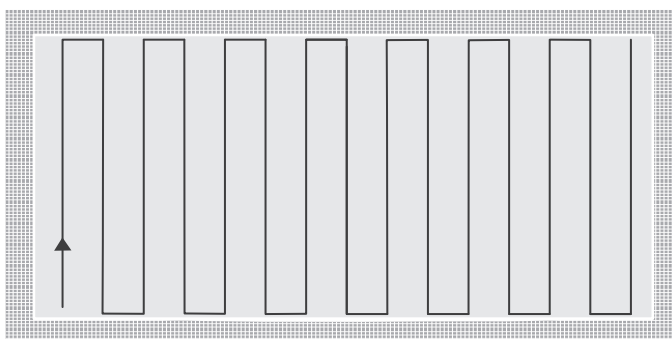
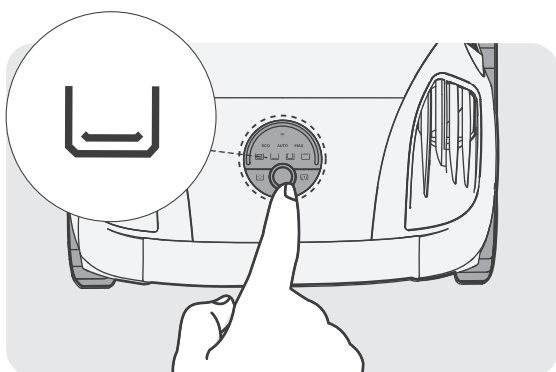

Floor Mode

- **Floor + Wall Mode:** The device will clean the pool floor and pool walls sequentially, while cleaning the walls, it will clean the waterline at the same time.

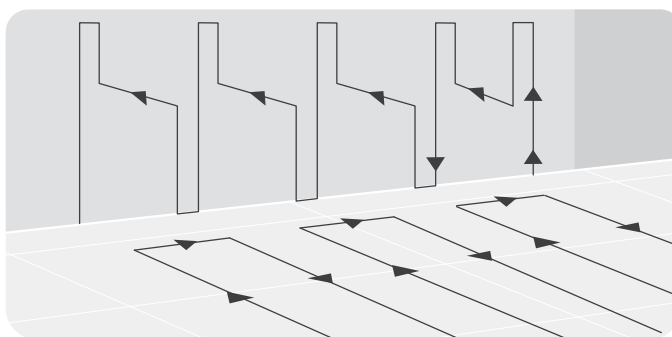
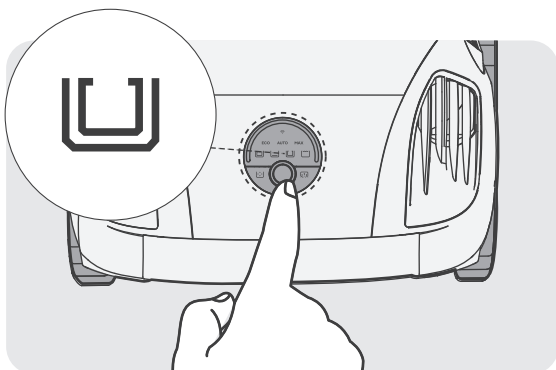

Floor + Wall Mode

- **Skimming Mode:** The device will clean the pool's water surface for 3 hours.

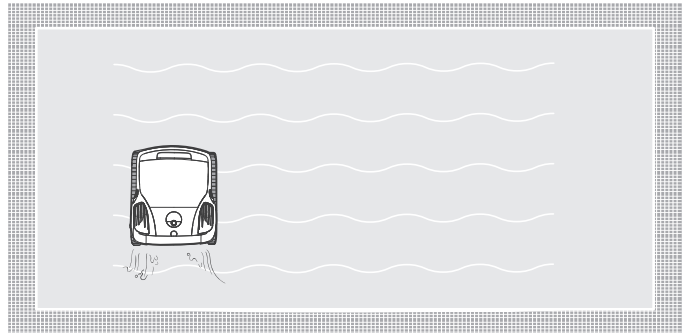
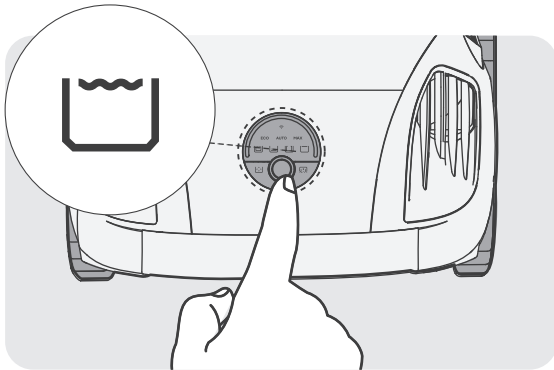

Skimming Mode

**Note:** The device's cleaning route may be updated with firmware versions. For the most accurate information, please refer to the device's actual performance or the latest official guidance.

### Cleaning Intensity Selection

**ECO:** Energy-saving mode. In this mode, the device will save energy, extending the device's cleaning time. Cleaning performance is not affected and can still clean debris such as sand, leaves, insects, etc.

**AUTO:** Adaptive mode. In this mode, the device will intelligently regulate the output and operation speed of the water pump according to the distribution of debris on the pool floor to get the balance of cleaning ability and battery life.

**MAX:** High-performance mode. In this mode, the water pump will work continuously at high power, providing great cleaning capability.

5. When the device completes a cleaning task, it will automatically ascend to the water's surface near the point of entry.

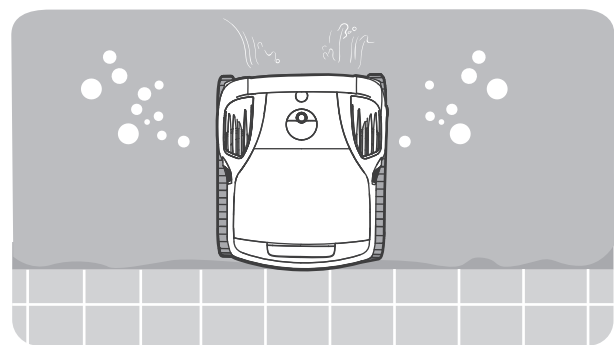
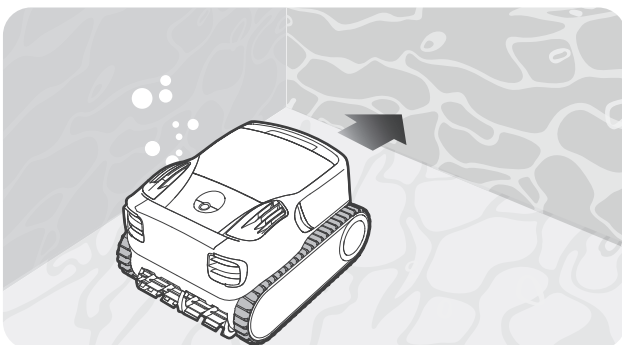

If, for any reason, the device doesn't ascend to the water's surface, attach the included hook to any standard telescopic pool pole (not included) to extend the reach. Hook and lift the device out of the pool.

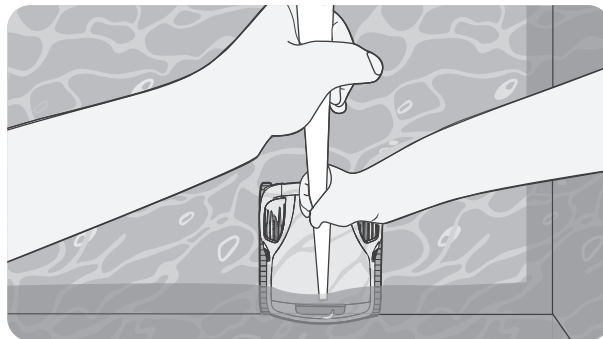
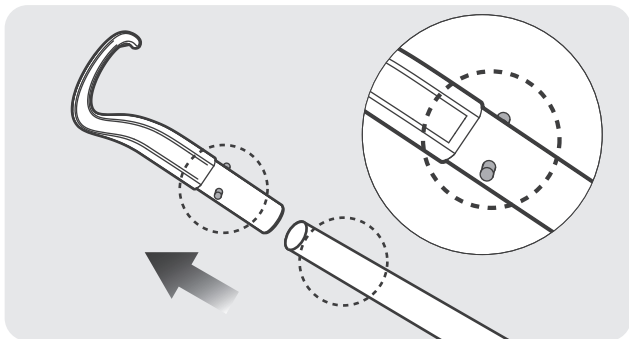

6. Allow the device to drain any stored water before storing or charging the device.



## 4 Maintenance

### 4.1 Cleaning the Filter Box

1. Place the device on a flat surface and lift the top shell.

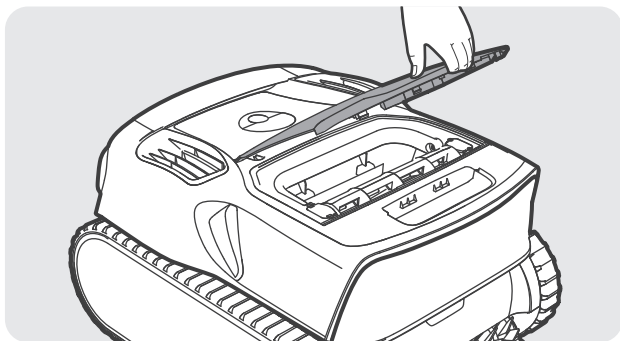

2. Remove the filter box by lifting its handle.

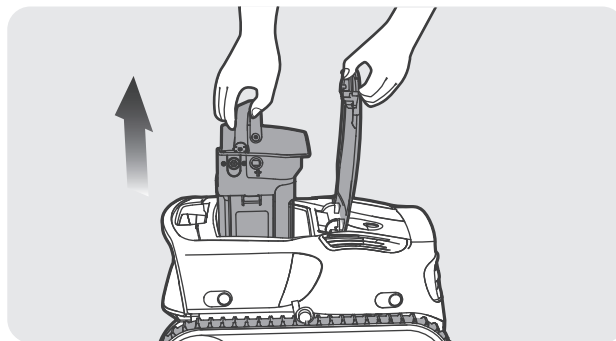

3. Press the latch on the bottom of the filter box and lift the top handle to open it.

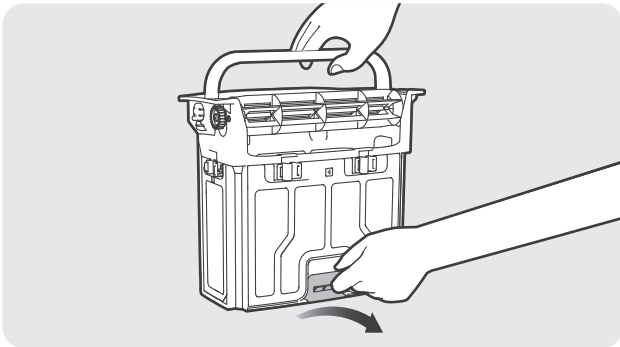

4. Empty, rinse and dry the filter box.

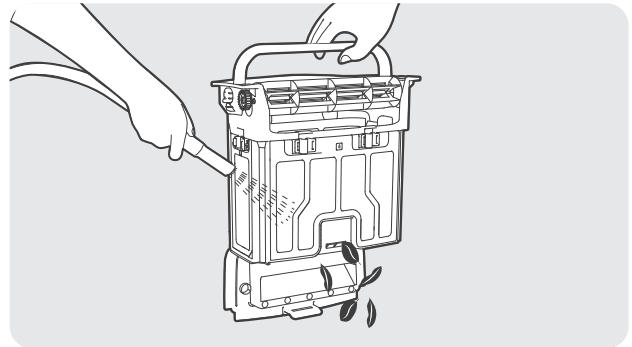

5. For a thorough cleaning of the filter box, press the latch to remove the filter.

**Caution:** Disassemble the filter strictly in the order shown in Figures 1–2.

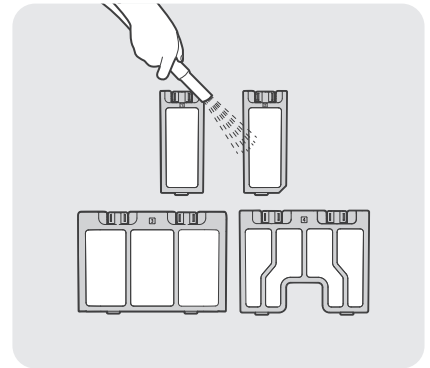
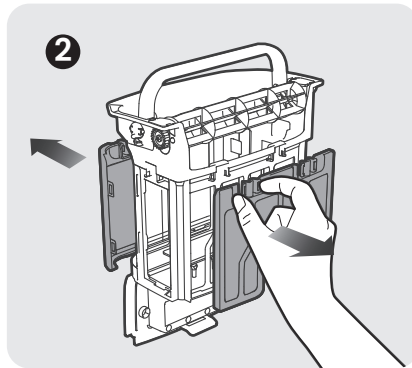
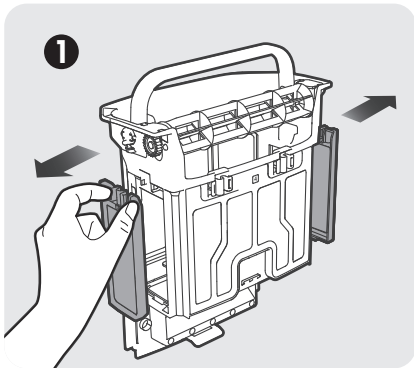

6. After drying, reinstall the filter and filter box into the device. Then press down on the handle until you hear a *click*.

**Caution:** Reinstall in the reverse order of removal.

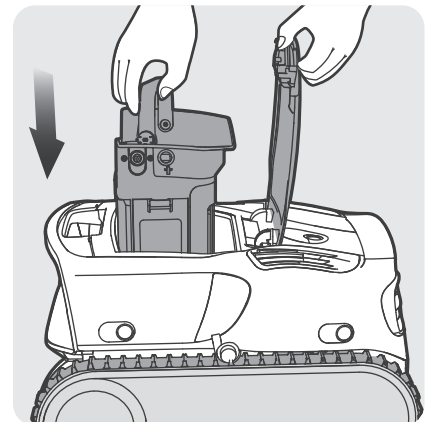
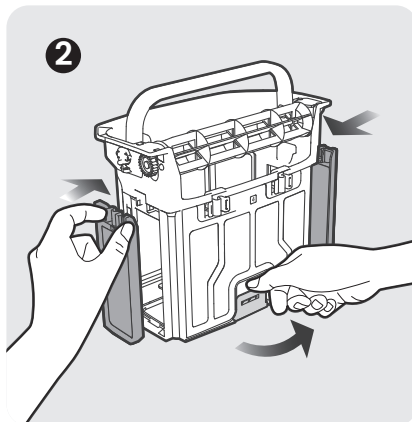
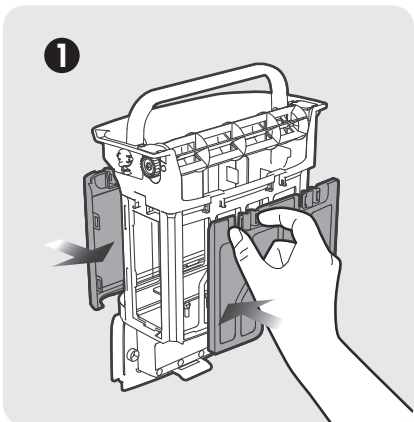

**Notes:**

- After each cleaning task, promptly remove the device from the pool and clean the filter box immediately. Avoid leaving the device in the pool for extended periods.
- Drying the filter and filter box after each cleaning is not required and is recommended solely to prevent moisture-related odors.
- When drying or storing your device, including the replaceable MicroMesh™ ultra-fine filter and filter box, it's recommended to store them in a well-ventilated area, out of direct sunlight.
- The replaceable MicroMesh™ ultra-fine filter traps particles as small as 3–10µm, such as silt and some algae. When visible debris is minimal (e.g., stones, leaves, sand, debris, hair) and the water appears cloudy or some algae, it is recommended to use the replaceable MicroMesh™ ultra-fine filter. If there is a significant amount of visible debris, it is recommended to use a standard filter.
- It is advisable to use a high-pressure water gun to clean the filter and the filter box to ensure thorough cleaning.
- After several uses, the surface of the replaceable MicroMesh™ ultra-fine filter may show signs of wear, which does not impact its performance.
- The replaceable MicroMesh™ ultra-fine filter is a consumable item and should be replaced every 30 uses to maintain effective filtration.

**4.2 Cleaning the Propeller**

1. Open the top shell and pry open the 2 screw covers with a flathead screwdriver.
2. After removing the screw covers, unscrew the 2 screws with a screwdriver, and then remove the top shell.

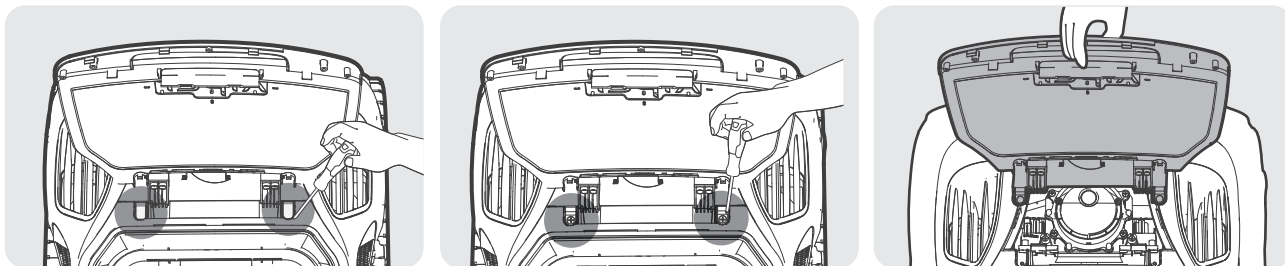

3. You will see the inside of the device. Disassemble the 2 screws to remove the propeller cover.
4. Clean the remaining debris, and reinstall the disassembled parts in order.

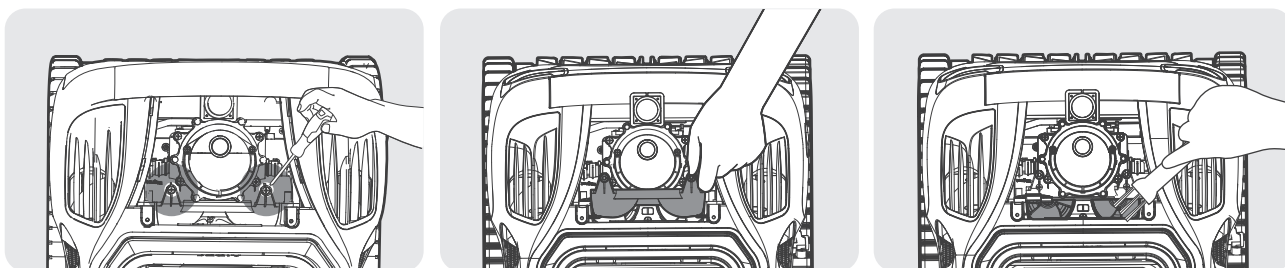

### 4.3 Cleaning Impeller / Water Surface Cleaning Impeller

1. Remove the filter box, and unscrew each of the 4 screws on the both sides of the filter box with a screwdriver.

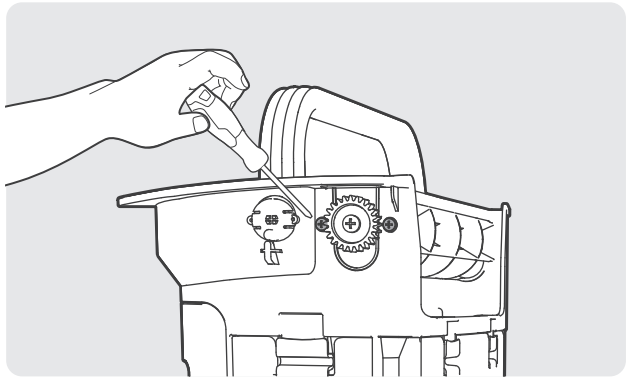

2. Pull the impeller upwards and remove it. While holding the impeller, unscrew the screws on the end.

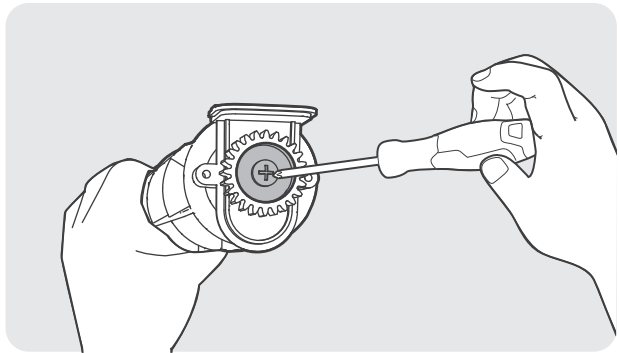
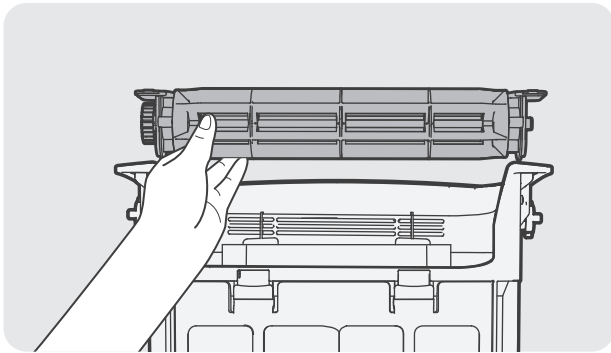

3. Remove the gear and the end cap in order, and clean the impeller.

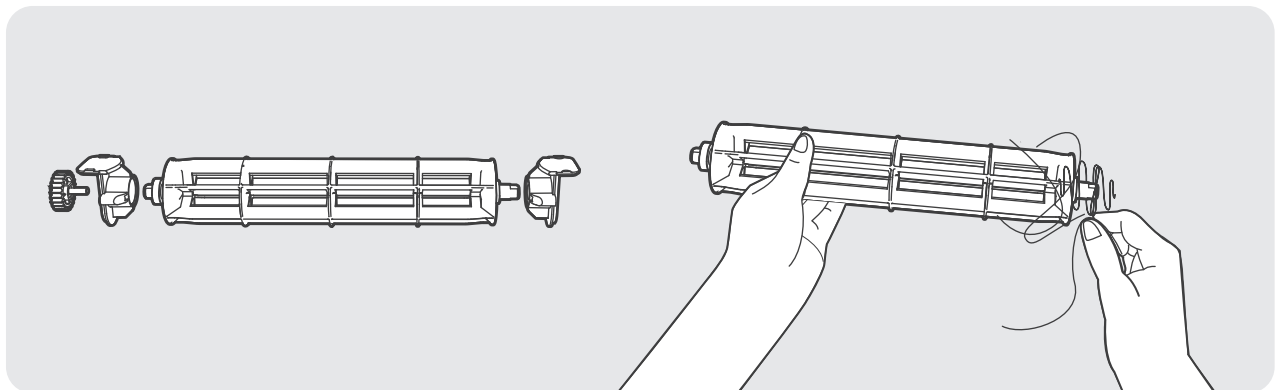

4. Reinstall the end cap and the gear in order, and secure all removed screws with a screwdriver.  
**CAUTION:** The ● on the impeller and the ■ on the end cap should be aligned with each other.

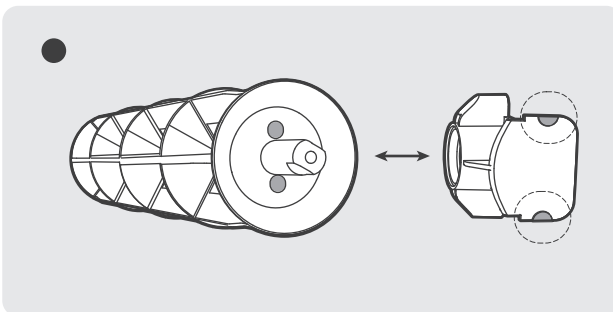
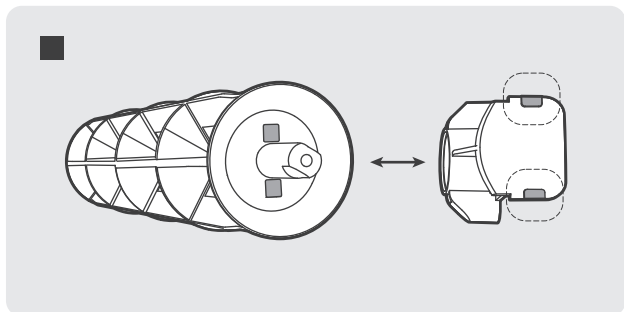

5. Insert the impeller into the filter box. Ensure that the ● on the end cap and the ■ on the filter box are aligned with each other. Attach and secure the 4 screws in order.

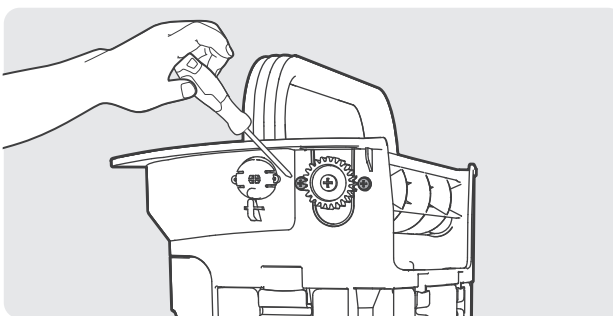
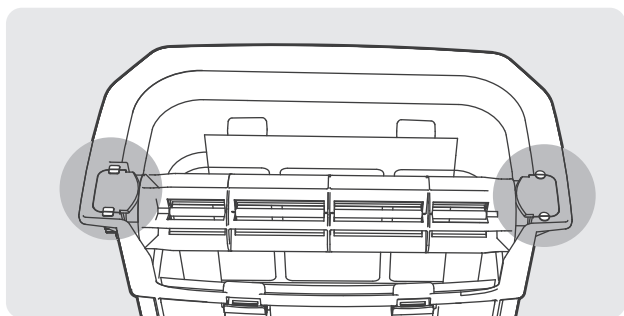

## 4.4 Replacing the Caterpillar Tread

1. Remove the side cover plate from the device: Lay the device on its side, press the 4 clips on the side cover plate inwards and pry them, and remove the side cover plate upwards.
2. Remove the screws and the guide sleeve from the rear wheel.

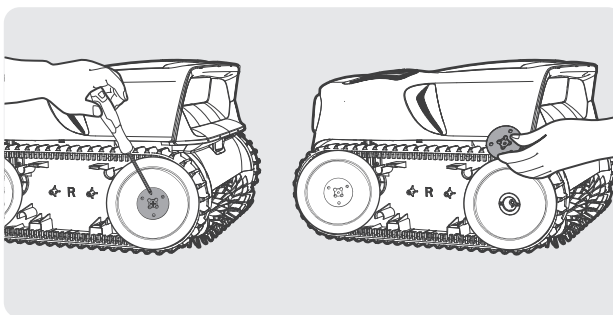
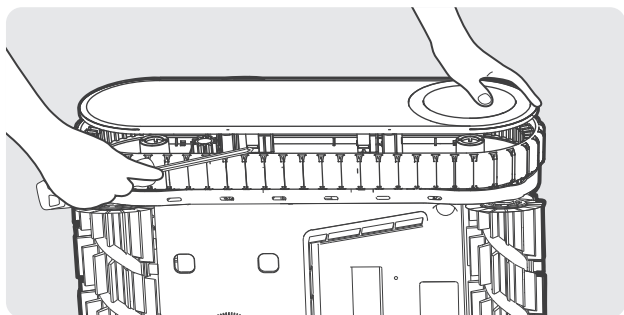

3. Remove the rear wheel and caterpillar tread of the device by gently pulling each piece.

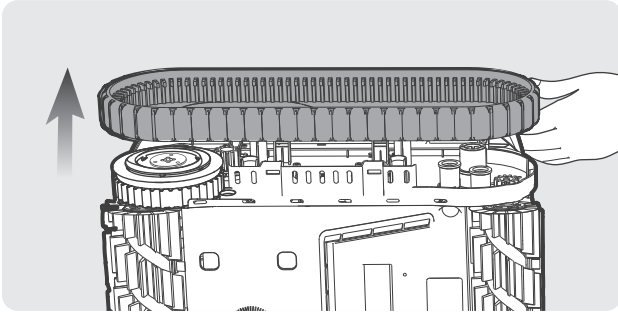

4. Align the gears of the replacement caterpillar tread with the gears on both wheels. Reinstall the rear wheel and the caterpillar tread, ensuring that they are secured along the tread sleeves.

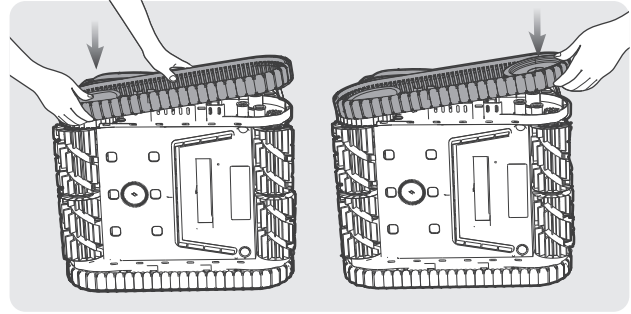

5. Install the rear wheel guide sleeve, and rotate the clip to ensure that the 2 bumps are aligned with the holes of the device.

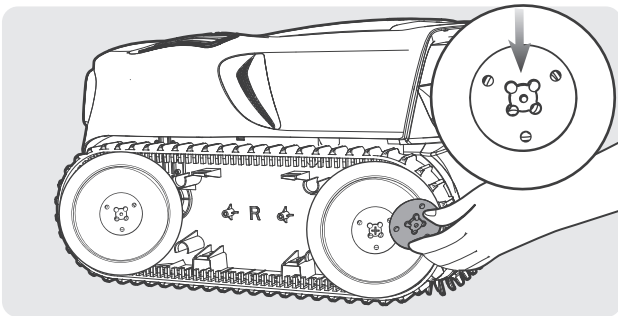

6. Tighten the screws and reinstall the side cover plate. Repeat this step for the other caterpillar tread.

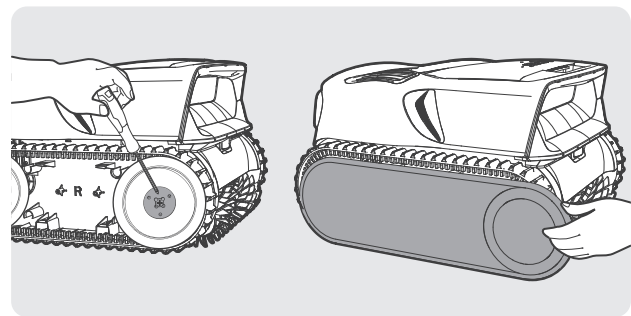

## 4.5 Replacing the Roller Brush

1. Remove all the silicone buckles from your current roller brush.

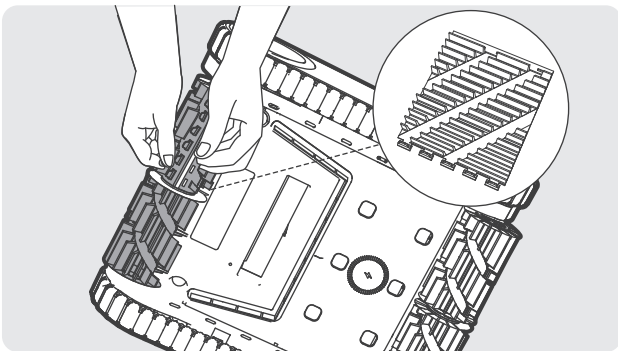

2. Once removed, take the replacement roller brush and align the silicone buckles with the slots. Press the buckles into each slot to secure the new roller brush to your device.

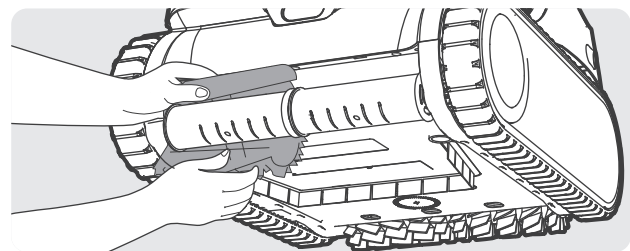

## 4.6 Powering Off and Storing Your Aiper









During off-seasons, such as winter or long vacations, when your Aiper device isn't in use, follow these steps to keep it in top shape:

1. Fully charge the device before storing it. Ensure the device is turned off and disconnected from the charger before storing.
2. Thoroughly clean the entire device, including the top and bottom shells, wheels and brushes to remove any dirt.
3. Dry the device with a tissue or soft cloth, and ensure the charging port cover is properly closed.
4. Store the device in its original packaging in a cool, dry, and well-ventilated place.
5. Recharge the battery every six months to maintain its health.



## 5 Specifications

Model: PRX9	Charging Time: 4 hours
Pool Size: 3230 Sq.Ft (300m <sup>2</sup> )	Suction Power: 8500 GPH (32000 LPH)
Rated Input: 29.4V==2.2A	Battery Pack Life: Up to 5 Hours - Floor, Up to 2.5 Hours - Wall, Up to 10 Hours - Skimming
Charger Model: GM95-294300-1FGN, GM95-294300-4FGN	Battery Pack Model: C1264B4-04 or C1264B4-03
Charger Input: 100-240V~, 50/60Hz, 2.5A	Battery Pack Capacity: 10400mAh (262.08Wh)
Charger Output: 29.4V==3.0A	Battery Pack Voltage: 25.2V
Wireless Charger Dock Model: CHW1	Water Protection Rating: IPX8
Wireless Charger Dock Input: 29.4V==3.0A	Max Water Depth: 10 ft (3m)
Wireless Charger Dock Output: 29.4V==2.2A	
2.4G Wireless Charger Dock Frequency Range: 2.400-2.480GHz, Maximum E.I.R.P: -12.94dBm	
Bluetooth Frequency Range: 2.4000-2.4835GHz, Maximum E.I.R.P: 10dBm	
2.4G Wi-Fi Frequency Range: 2.4000-2.4835GHz, Maximum E.I.R.P: 20dBm	

Energy Efficiency	Power (W)	Period Before Entering This Mode (min)
Off Mode	0.31	15

	Direct current.		Switch mode power supply.
	Alternating current.		Read user's manual.
	Class III equipment.		Max water depth.
	Polarity of d.c. power connector.		
	Short-circuit-proof safety isolating transformer.		
	For indoor use only.		

## 6 LED Indicator

Indicator Types	Indicator Status	Status Description
LED Status Indicator	Pulsing Blue	Remote Control Mode.
	Pulsing Green	Charging.
	Solid Green	Charging Complete.
	Pulsing Yellow	To Reset the Device: Hold  +  for 5 seconds. The device will then be restored to its factory settings.
		OTA in Progress: The device is automatically updating to the latest firmware.
	Flashing Red	The device is faulty. Please follow the App's instructions for troubleshooting.
	Solid Red	Low battery level (Battery < 15%). Automatic shutdown soon.
	Solid Blue	Moderate battery level (Battery 15%-30%).
Solid Green	Sufficient battery level (Battery > 30%).	
Wi-Fi Indicator	Pulsing Green	Connecting to Wi-Fi.
	Solid Green	Wi-Fi Connected.
	Off	Wi-Fi Disconnected.

## 7 Troubleshooting

NO.	Malfunction	Possible Causes	Solutions
1	Device doesn't turn on.	Insufficient battery power.	Fully charge the device before using it.
		Battery temperature too high/low.	Only operate the device in an environment between 32°F (0°C) and 104°F (40°C).
2	Device not charging.	The device is not in place.	Replace the device. Ensure that the bump on the charger is fully inserted in the device inlet.
		Charger is damaged or not powered.	Check if the charger plug is securely connected and if there is a <i>beep</i> sound after plugging in the power supply. If the plug is connected correctly but there is no <i>beep</i> , the charger may be faulty. Please contact Aiper customer service.
		Battery temperature too high/low.	Only operate the device in an environment between 50°F (10°C) and 104°F (40°C).
		Extended non-use of the device has caused the battery to discharge.	Follow the <i>Powering Off and Storing Your Aiper</i> section in the <i>Maintenance</i> guide for proper storage of the device. If the device won't charge due to extended non-use, please contact Aiper customer service.
3	Device doesn't avoid obstacles.	Sensor lens is dirty.	Use a soft, dry cloth to clean the sensor lens to prevent obstructions.
4	Device remains on the pool drain for too long.	The device has been caught by the pool drain.	Do not open the pool drain while the device is cleaning. If stuck, the device will free itself.
5	Device stuck at waterline in Waterline Mode.	Small protrusion at waterline not detected by sensor.	No action is required; the device will sink to the pool bottom within 1 minute and continue cleaning after avoiding waterline obstacles.
6	Device tilts or shows decreased cleaning performance in water.	Filter box is full.	Please empty and thoroughly clean the filter box.
		Filter is clogged.	Please rinse the filter with a high-pressure water gun.
		If the LED status indicator is flashing red, the propeller may be jammed.	Check for any debris on the propeller and clean it if needed. For details, refer to the <i>Maintenance</i> section for <i>Cleaning the Propeller</i> .
7	Device has stopped working.	If the LED status indicator turns solid red, the battery is low.	If the cleaning task ends early, the device may have been low on battery. Ensure the device is fully charged before use.
		If the LED status indicator is flashing red, the device may be faulty.	Please follow the App's instructions for troubleshooting.

## 8 Warranty

This product has passed quality control and safety test conducted by our technicians.

1. This product comes with a 36-month warranty that covers your item's battery and motor from the date of purchase.
2. This warranty is voided if the product has been altered, misused, or has been repaired by unauthorized persons.
3. This warranty extends only to manufacturing defects and does not cover damage resulting from the mishandling of the product by the owner.
4. The order number or record of purchase must be presented at the request of any repair claim during the warranty period.

### Manufacturer

Shenzhen Aiper Intelligent Co., Ltd.

Units 3201, 3203A and 3205, 32nd Floor, Block C, Phase 2 Galaxy World, Minle Community, Minzhi Street, Longhua District, Shenzhen, Guangdong, China, 518129

CN Tel: +8675521018957 Email: [service@aiper.com](mailto:service@aiper.com) [www.aiper.com](http://www.aiper.com)

Merci d'avoir choisi Aiper.

Vous avez rejoint les millions de personnes qui ont fait confiance à Aiper pour profiter d'une piscine parfaitement propre.

Ce manuel d'utilisation vous aidera à entretenir votre appareil pour garantir une efficacité maximale de ses performances pendant des années. Merci de bien vouloir prendre le temps de le lire intégralement.

Si vous avez des questions, veuillez consulter notre site Internet à l'adresse [www.aiper.com](http://www.aiper.com) et contacter notre service après-vente pour obtenir de l'aide ou plus d'informations.

### Service après-vente Aiper :

Pays	Numéro vert	Langue
États-Unis	+1 8668500666	Anglais
Canada	+1 8668500666	Anglais
Australie	+61 1800497023	Anglais

✉ Adresse e-mail : [service@aiper.com](mailto:service@aiper.com)



Scannez pour obtenir une vidéo d'instructions



Scannez le code QR pour accéder au service après-vente